

Khataraha

Ilaha Gaaska Dabiiciga ah



**Digniin ku
saabsan
Gaaska ololi kara**

- Gaaska daadata wuu qarxi karaa, wuxuuna sababi karaa dab.
- HA gelin ama isla markiiba ha ka bixin guri uu kasoo urayo gaaska dabiiciga ah (ur ukun qudhuntay oo kale).
- Gaasku wuu daadanayaa haddii uu soo urayo, maqasho neefta gaaska, ama aad aragto dhaqdhaqaaqa mitirkaaga gaaska oo wareegaya.

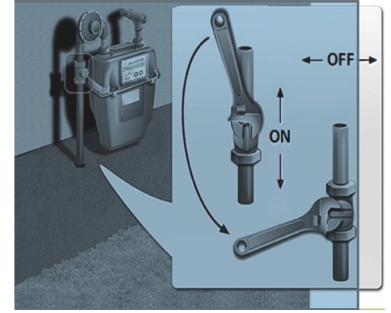

Haddii uu daadinayo:

- Isticmaal fur ama aalad kale si aad u xirto tuubada mitirka gaaska 1/4 u leexo si madaxa madaxa tuubada uu uga gudbo tuubada soo qaada. Way adkaan kartaa in la soo leexiyo.
- Ha isticmaalin aalad koronto ah ama aalad kasta oo u keeni kara dhimbilo u dhow mitirka gaasta. HA daminin gaaska ilaa inuu ka daadinayo moogiye! Shirkadda gaasku waa inay kuu soo celisaa, waxaana laga yaabaa inay wakhti dheer qaadato ilaa inta ay kusoo celinayaan.

Halista Koronto ahaaneed

- Kusoo wargali wixii dab ka kacay tiirarka korantada 911 ama xarunta dab-damiska.
- HAKA daminin korantada meelaha laga damiyo iyada oo daaran guri ay dhici karto inuu gaas daadanayo, dhimbiiluhu waxay sababi karaan qaraxa gaaska.
- Ka saar alaadaha yaryar, iyo waxyaalaha aan loo galinin meel la ilaaliyo badqabka xarig koronto. Ka tag iyadoo daaran si aad u ogaato marka korontada soo laabato.
- MARKASTA ula dhaqan xarkaha korontada ee hoos ku jira inay yihiin KUWA KORONTO LEH - xataa haddii aad u malaynayso in korontadu maqan tahay - ka fogaw ugu yaraan 20 fiit!



Agabyada Halista leh

- KA DIGTOONOW qiiqa sunta ah ee ka yimaada waxyaabaha daatay iyo kuwa la isku qasay. Haddii aad dareento saameyn jiro ahaaneed, ka tag goobta Isla markiiba.
- Ku calaamadee waxyaabaha daatay dareerayaasha lagu nadiifiyo, shidaalka iyo walxaha kale si aad u ilaaliso kuwa kale.
- Nadiifi waxyaabah daatay, haddii ay ammaan tahay in sidaas la sameeyo, ama ku dabool wasakh ama walxo aan guban karin.
- Raadi oo nadiifi daawooyinka daatay iyo khataraha kale ee halista ku ah carruurta iyo xayawaanka rabaayada ah.

Ka digtoonow Dhismayaasha

Burbur Muuqda

Dhulgariir kadib, waxaa dhici karta in ay dhacaan dhul gariiro kuwaas oo sababi kara waxyeelo kale- iska eeg dhismayaasha ka hor inta aanad dib u soo galin!

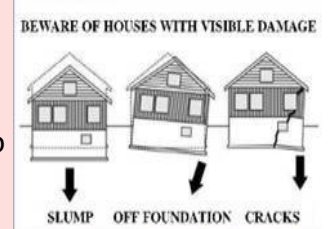

Dhumaha gaaska

- Ka eeg dhumaha gaaska haddii uu dhaawac yahay.
- Darbiga dhumaha gaaska way daciifin doona gariir waxaana laga yaabaa inay ku dunto gariir koronto ahaaneed kadib.
- Haddii dhuunta gaaskaagu daawacantay, iskaga fogaw.
- Ha isticmaalin goobra dabka lagu shido ilaa dhuunta gaaska la hubiyo.

Shaqayn la'aanta dhumaha xakameeya socodka gaaska

Ka war hay goobaha shaqayn la'aanta dhumaha xakameeya socodka gaaska la saadaaliyay. Gariirada koronto kadib ama xaaladaha ka sii dara waxay sababi karaan daahitaanka huumaha xakameeya socodka gaaska.

Ogaysiimaha Qaab-dhismeedka iyo Badqab ahaaneed

- **Kaararka ogaysiin ahaaneed ee cagaaran** iyo kuwa, **Jaalle ah**, marka baaristu ay dhici karto, waxay kuu sheegi doontaa ilaa xadka fogaansho ahaaneed ee dhismahaaga lagu degi karo.
- **Kaararka** Guduudka ah: Lama soo geli karo xaalad kasta!